

CARGO FLOOR®

Additional assembly instructions

Semi Leak Proof SLP

INTRODUCTION

The assembly instructions outlined in this book will enable you to assemble the Cargo Floor system you have purchased correctly. Every effort has been made, by means of diagrams and text, to ensure a clear and simple installation. To ensure the durability and reliability of this revolutionary loading and unloading system, it is important that you follow the assembly instructions as outlined in this book completely, and use quality materials in accordance with the specifications. Please note that the guarantee is only valid if the Cargo Floor system has been assembled in accordance with these assembly instructions. The latest available version can always be found on our internet site:

www.cargofloor.com

Downloads

The measurements given in this instruction start with the metric system after which between brackets [0] the imperial measurement is mentioned.

(ADDITIONAL) INSTRUCTIONS

The following (additional) instructions are available next to these instructions:

Assembly CF100 SL-C system

Assembly CF500 SL-C Power Speed system

Assembly CF500 SL-C Leak Resist Centre drive

Assembly CF3 LP-2 15-160

Assembly CF800 system

Assembly steel C-vloer

The latest available version can always be found in the downloads section on our internet site:

www.cargofloor.com

TABLE OF CONTENTS

Introduction 2
 (Additional) instructions 2
 Table of contents..... 3
 Important recommendations and guidelines for the commissioning..... 4
 Cutting the floor profiles to size10
 Determine the position of the holes in the profiles11
 Drilling the holes in the floor profiles.....12
 Mounting the seal and sealblock15
 Securing the floor profiles to the drive unit.....16
 Securing the stationary side profiles.....16

TABLE OF CONTENTS OF THE ENCLOSED DRAWINGS

Subject	Drawing
Example fixating the loos gutters	V102601-CF-250ra
Example adjustment	V102602-CF-251ra
Impression Floor survey	V101012-CF-201rb

IMPORTANT RECOMMENDATIONS AND GUIDELINES FOR THE COMMISSIONING

Before putting the Cargo Floor loading and unloading system into operation, follow the recommendations provided below and check the specified checkpoints to avoid damage to the Cargo Floor system and the vehicle.

Please review the important instructions before operating the Cargo Floor system and loading cargo into the vehicle. Likewise, before loading cargo, check the operation of the various control switches/valves to familiarize yourself with how the system works. We strongly recommend that you perform these checks when picking up the vehicle from the dealer so that a resident expert can answer your questions and provide you with any necessary advice or guidance you may require.

Important:

- Always check that the selected loading or unloading direction is actually activated and occurring!!
- If the system fails to start, turn off the Cargo Floor system and the hydraulic pump and follow the recommendations and guidelines provided below. Do not repeatedly try to start the system as this may result in damage to your Cargo Floor system and/or vehicle.
- After use, turn off the Cargo Floor system and hydraulic pump. Set switches to the "[0]" position and the lever in neutral.

In case of doubt or uncertainty about these recommendations and guidelines, always contact your dealer or an official workshop.

The Cargo Floor system comes standard with an operating manual, but if this has not been supplied, please contact your dealer or download it from the official Cargo Floor website:


WWW.CARGOFLOOR.COM


- A) Always open the vehicle's doors before turning on the hydraulic pump. Note! Build-up of pressure against the doors can force them open, which may cause some of the cargo to fall out of the vehicle. That is why it is always advisable to use the pneumatic lock, if provided.
- B) 1. Check that the vehicle's (quick-detachable) couplings are properly connected to the P (Pressure line, min. 20mm [$\frac{3}{4}$ "]) and the T (tank/return line, min. 25mm [1"]). Also check that the couplings are fully tightened or slid completely into each other.



IMPORTANT: the pressure and return line connectors may not be reversed or exchanged to prevent dirt or water from entering the lines when connecting them!

2. Before connecting, check that the non-return valves can open easily (check: the non-return valves should open easily when pressed with the finger, if not, potential pressure build-up in the hydraulic lines may be preventing the system from starting).
NOTE: Incorrectly connected or unopened hydraulic couplings will cause serious damage to the Cargo Floor system and the vehicle.
- C) The vehicle (pump) must be fitted with a pressure relief valve that is set to 250 bar [3,625 psi]. If fitted, check that the dual-function lever (function: tipper/Cargo Floor) is in the Cargo Floor position. Pressure may not exceed the maximum adjusted and allowable operating pressure of the Cargo Floor system. An incorrectly adjusted pressure relief valve can cause damage to the Cargo Floor system and the vehicle.
- D) During operation, the (hand) brake of the vehicle must always be applied. You must, however, move the vehicle forward on time to unload it quickly in order to prevent unnecessary strain and wear to the floor and the vehicle.
- E) Use of a wireless remote control is permitted only if it is fully tested before the start of each loading or unloading operation. Always check if the function you have selected is actually activated and taking place. If, for example, you have accidentally pressed the load function when you actually meant to press the unload function, irreversible damage may occur to the Cargo Floor system and the vehicle.
- F) During operation of the Cargo Floor system, all existing STOP and control knobs/levers must be freely accessible.

- G) The pressure filter element needs to be replaced at least once a year. If the couplings between the vehicle and the Cargo Floor system are regularly removed, it is advisable to check the pressure filter for dirt build-up and replace the pressure filter element more often, if necessary. If provided, also check the return filter (not supplied with the Cargo Floor). Failure to replace a filter element on time may cause damage to or malfunctions in the Cargo Floor system and the vehicle.
 - H) Moving parts must be shielded. Always maintain at least 10m [30'] distance from the Cargo Floor system when it is in operation.
 - I) In the event of malfunctions/maintenance work, you may approach the Cargo Floor system only if all equipment, including the hydraulic pump, has been shut off, and the Cargo Floor system and the electro-hydraulic aggregate have been disconnected from the power supply and pump.
 - J) Regularly check and, if necessary, tighten any loose bolts that secure the aluminium floor profiles to the Cargo Floor system. All such checks can simply be performed inside the vehicle itself by qualified personnel. The Cargo Floor system must, however, be turned on in unloaded condition and the person performing the check must place his finger half on the floor profile and half on the bolt. There should be no appreciable movement/space between the floor profile and bolt. Failure to check these bolts may lead to damage to the Cargo Floor system. During this check, a second person must also be present to switch off the Cargo Floor system.
 - K) Check that the minimum required amount of oil is present (150L [40 gallon]). Too little oil in the hydraulic tank will cause damage to both the pump and the Cargo Floor system.
 - L) Do not allow the number of strokes to exceed the maximum allowable 16 power strokes per minute. Only a Power speed Cargo Floor system may deliver up to 23 beats per minute. A higher number of power strokes can cause damage to the Cargo Floor system and the vehicle.
 - M) Hydraulic lines, couplings and hoses with very small diameters will cause damage.
 - N) If the Cargo Floor system fails to start or operates incorrectly, the Cargo Floor system and the hydraulic pump must be shut down immediately. Subsequently, check all the checkpoints before switching the pump and the Cargo Floor system back on. To prevent the oil from overheating, regularly check the oil temperature touching them right away.
-  **WARNING: TOUCHING OVERHEATED OIL AND COMPONENTS CAN CAUSE BURNS!**
- O) The cause of failure or malfunctioning of the Cargo Floor system may also be due to other hydraulic components that may or may not be connected to the same hydraulic circuit of the Cargo Floor system.
 - P) Jamming of the floor profiles caused by the transport of abnormal loads and or the freezing of the floor or of the product to the floor may result in damage to the Cargo Floor system and the vehicle. Recommendation: in the event of freezing, stop the system and try to find a hall (heated area) to allow the product to thaw.
 - Q) Because the electrical power supply of the Cargo Floor system is often connected to the lighting circuit of the vehicle, it is advisable to turn on the lighting throughout the operation of the system.
 - R) Maintenance and repairs to the Cargo Floor system may be only performed by qualified personnel. Use only original Cargo Floor components to ensure maximum reliability and long service life.
 - S) Maximum cargo weight is subject to the limits set by law and applicable regulations. Even if the system can transport heavier loads, the law determines the maximum limit. Excessively heavy cargo can cause damage to the Cargo Floor system and the vehicle.
 - T) Check that the correct type and quality of hydraulic oil is used. The use of incorrect oil type may cause damage to the Cargo Floor system and the pump.
 - U) Check the vehicle for correct voltage. Make sure there are no open electrical connections. A faulty electrical system can cause damage to the Cargo Floor system and the vehicle.
 - V) Check that the bulkhead, if present, is functioning smoothly and properly. A properly functioning bulkhead ensures that the product is unloaded in a clean and quick fashion. A malfunctioning bulkhead may extend the unloading time and cause damage to the vehicle.
 - W) Use of the Cargo Floor system by unqualified personnel can cause damage to the Cargo Floor system and the vehicle.
 - X) Excessively high oil temperatures will cause damage to the Cargo Floor system and other hydraulic components, such as the pump.

- Y) It is at all times advisable to stop the Cargo Floor system when all the piston rods are retracted. This is usually the case when the floor profiles are positioned towards the unloading end (vehicle doors). Unretracted piston rods may cause damage to the Cargo Floor system.
- Z) To prevent damage to the floor profiles, exercise caution and limit the dump height as much as possible. The transport of unauthorized goods, such as aggressive, corrosive, hot, hard, sharp and viscous materials may cause damage to the Cargo Floor system and the vehicle. Avoid loading and unloading sharp objects. Loads that are softer than the hardness of the floor profiles will extend the service life of your system; if in doubt use a protective cloth or consult your dealer.
- AA) Forklift trafficable. In principle, the floors are completely trafficable and can be driven over by forklifts, but always consult your dealer for advice on the maximum loads allowed on your vehicle. Overloading will cause damage to the Cargo Floor system and the vehicle.
- BB) Always return emergency control(s) to their original non-activated position after use.
- CC) During the operation of the system, test the temperature of the oil by touching the side of the tank. If the oil is so hot that you cannot continue to touch the tank, switch off the pump to allow the oil to cool off and determine what is causing the overheating. Stop loading or unloading if the oil is too hot, as this will **WARNING: TOUCHING OVERHEATED OIL AND COMPONENTS CAN CAUSE BURNS AND INJURIES!**
-  DD) During loading and unloading operations, the load should be spread to give an even weight distribution over the floor area, otherwise the load may stall. Tip: when transporting pallets, place softwood boards of 300 x 18 x 2350 mm [12" x 0.75" x 92.5"] to distribute the pressure more evenly.
- EE) The constant pressing of the load against the head board or the doors can lead to extra wear of the complete system. Also the construction can be damaged. Please consult your supplier about the optimizing possibilities or in order to prevent problems occurring.
- FF) The user/operator/driver that is operating the Cargo Floor system is compelled to remain a safe distance from the Cargo Floor system at all times, from the time of switching on the hydraulic pump until turning it off. He should ensure that no dangerous situations can occur. When the process malfunctions or if other people are present he should shut down the Cargo Floor system, or hydraulic pump, immediately.

WARRANTY:

Warranty is subject to prior approval by Cargo Floor B.V.! To request warranty coverage, visit www.cargofloor.com to fill out and submit the warranty application form provided there; do not forget to include your Cargo Floor system number on the form.

In the event of an **EMERGENCY**, operation of the Cargo Floor system can be halted as follows:

- ◆ By pressing the stop button on the wired remote control unit;
- ◆ By turning all switches to position "0";
- ◆ By putting the handle of the control valve in the middle position (only B and A control);
- ◆ Turning off the pump;
- ◆ Turning off the main switch of the power supply;
- ◆ Turning off the motor of the electro-hydraulic aggregate;

This WARNING STICKER/DECAL has been supplied with the drive unit in two fold. It should be attached near the control box and on the rear door in such a way that it is easy to read.



 If the indications in this manual, as well as those stated in the user manual, are not followed this could result in damages and/or injuries.

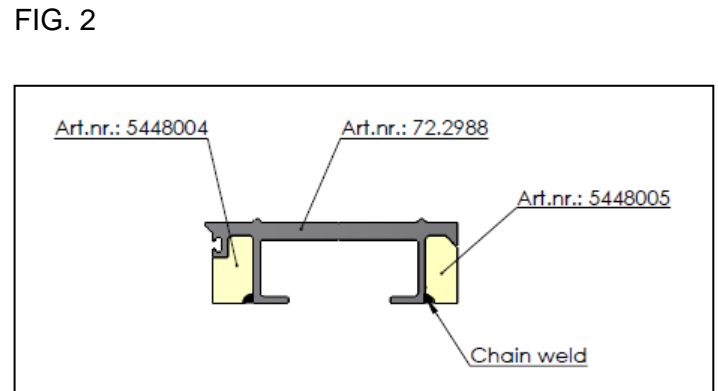
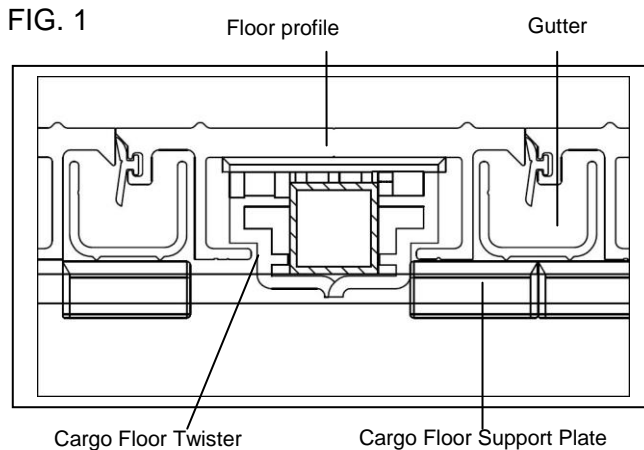
GENERAL INSTRUCTIONS

The application and installation of a SLP floor demands a number of different steps in relation to a standard floor.

Next to this the construction of the trailer also demands some adjustments to collect the leakage fluid transported by the channels. For general assembly instructions please see our assembly instructions for the CF500 SL-C.

The SLP floor consists of various components:

- The floor profile (the moving plank);
- The gutter (standing still);
- The bearing (Twister) or alternatively a plastic guide comb or block if no 25 x 25 [1"x1"]tube is used in the construction;
- The Cargo Floor Support Plate (support/guiding of the channel);
- The end cap (5164004.1);
- The sealing profile (seal between the profiles);
- The alu side closing profile L.=220mm SLP seal side (5448004) for the finishing of the aluminium floor profiles;
- Alu side closing profile L.=220mm SLP NOT seal side (5448005).



The advantage of the Cargo Floor SLP floor solution with exchangeable channel is that in case of extreme pollution of the channels these can be removed for cleaning without demounting and mounting the complete floor.

In the following description we will indicate, in a number of steps, the differences, the necessary adjustments and the points of interest.

THE TRAILER

As well as the standard Cargo Floor systems the SLP floor can be mounted in the same kind of trailers. Also the pitch of the profile (112 mm. [4.4"]) is the same as the standard floor profiles. Nevertheless a number of adjustments are required to avoid leakage outside of the liquids collected in the channels of the floor.

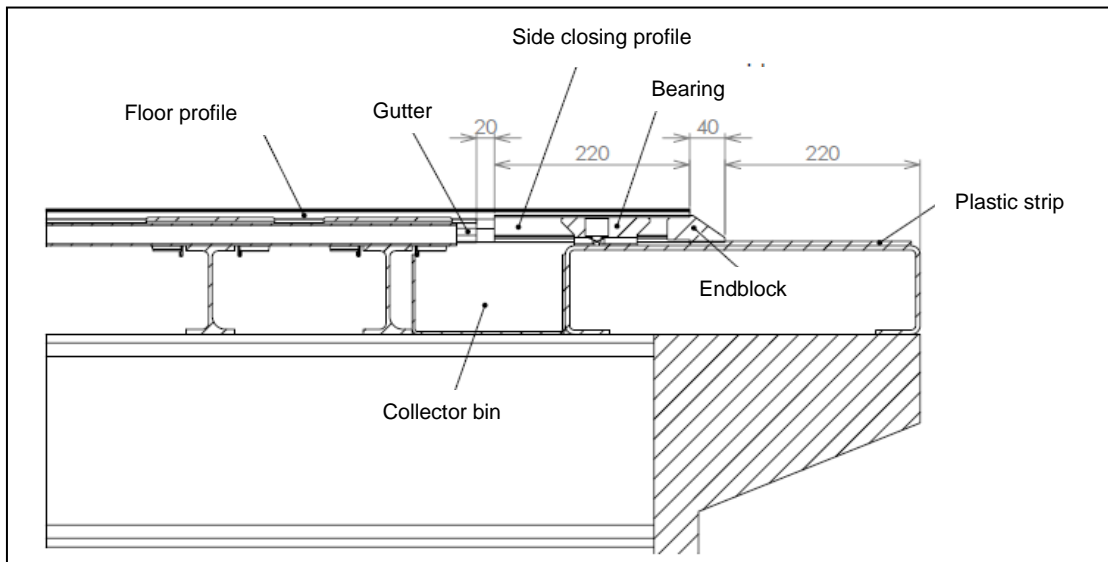
REAR OF THE TRAILER

At the rear of the trailer a collector bin for the fluids has to be made. The volume of this collector depends on your customer's demands and is therefore not a fixed item. The volume of the 22 channels is approx. 165 litres [43 gallon] with a normal trailer length.

Because of the working stroke of the floor profiles and the aluminium seal which has to be placed at the end the profile, the channel has to stop approx. 480 mm. [18.9"] for the back doors of the trailer.

In the space behind the last bearing the collector can be positioned.

FIG. 3



FRONT OF THE TRAILER

At the front of the trailer 21 holes have to be made, which should be so big that after the finishing a hole remains with a minimum diameter of 40 mm. [1.6"]. Through these holes the channels can be removed to be cleaned.

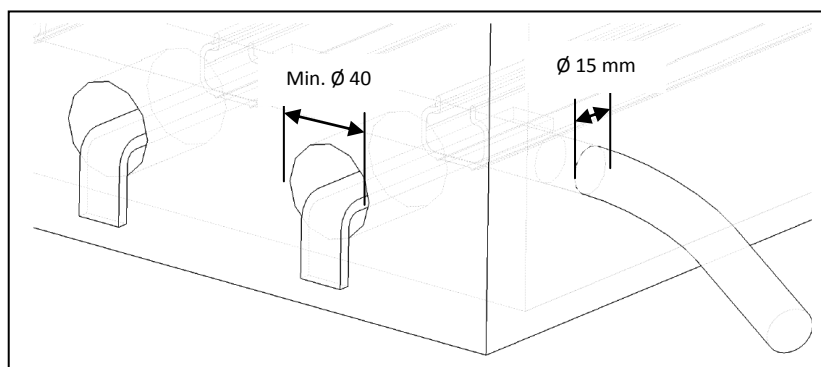
Because the walls are hollow pipes have to be welded in the holes. The inner diameter of these pipes has to be at least 40 mm. [1.6"].

As a detent for the gutters we advise you to put a bar through from the side of the trailer. Pay attention to that the bar also needs a detent in order to prevent it from loosening. For this a hole has to be drilled through the side frame profile through which a 12 mm. [0.5"] diameter bar fits. The hole needs to have a diameter of 15 mm. [0.6"].

Fig. 4 is a principle drawing about how to realize this.

Of course there are other methods to fix the channels. You can weld a small plate at the short end of the gutter lying outside the headboard. This plate can be fastened individually or together (all gutters) at the headboard.

FIG. 4



CUTTING THE FLOOR PROFILES TO SIZE

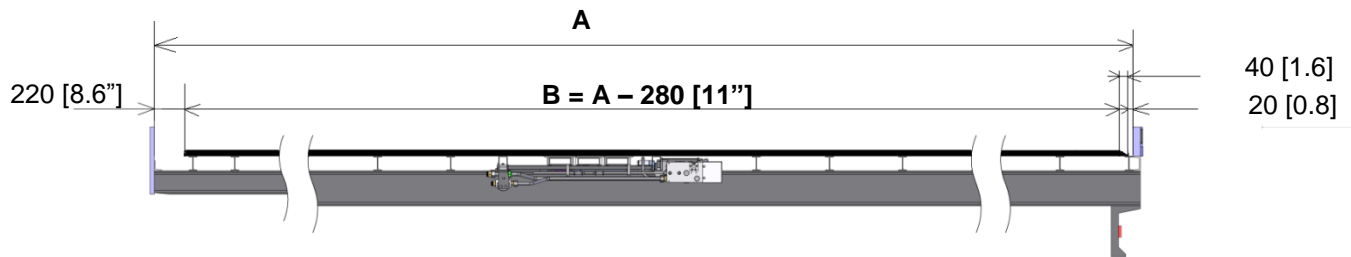
The aluminium floor profiles can be cut to size according fig. 5 after the plastic bearings have been mounted.

Pay attention to the fact that the floor profiles must be shorter than the inner measurement of the construction, and take into account whether the door is inside or outside the tailgate.

A space of 40 mm. [1.6"] should be adhered to at the rear for the end block.

A space of 20 mm [0.8"] should be adhered to at the front and the rear of the construction.

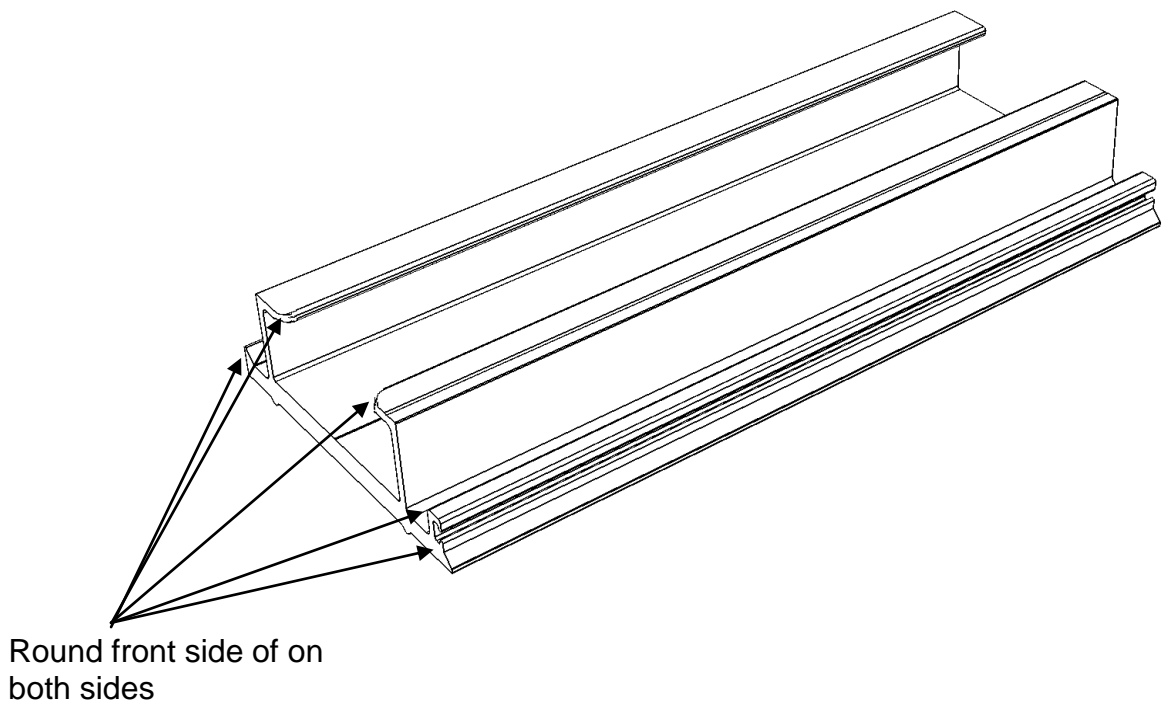
FIG. 5



After cutting the floor profiles to length they need to be rounded-off (beveled) at the front as to ensure a smooth guiding of the floor profile while sliding in, and to prevent damage to the plastic bearing.

To aid mounting, the rounded-off (beveled) side needs to lie in the mounting direction of the vehicle

FIG. 6



DETERMINE THE POSITION OF THE HOLES IN THE PROFILES

First you need to determine the position of the holes in the profiles, see fig. 19.

Check if the cylinders are fully retracted. You check this as follows: the ends of the piston rods may not protrude out of the guide block for cylinderbar more than 5-10 mm. [0.20-0.39"].

Take into account that with a bundle floor profiles there could also be a double seal profile supplied. This profile should be mounted fully to the left (1st group) or fully to the right (3rd group). Divide the remaining 20 profiles into 3 groups (1 group of 6 profiles and the double seal profile, 2 groups of 7 profiles).

The position of the first hole is determined by taking the measurement from the inside of the door side to the first hole in the U-profile moving crossmember of the third group. From this measurement you deduct 60 mm [2.4"] and with this you have determined measurement A.

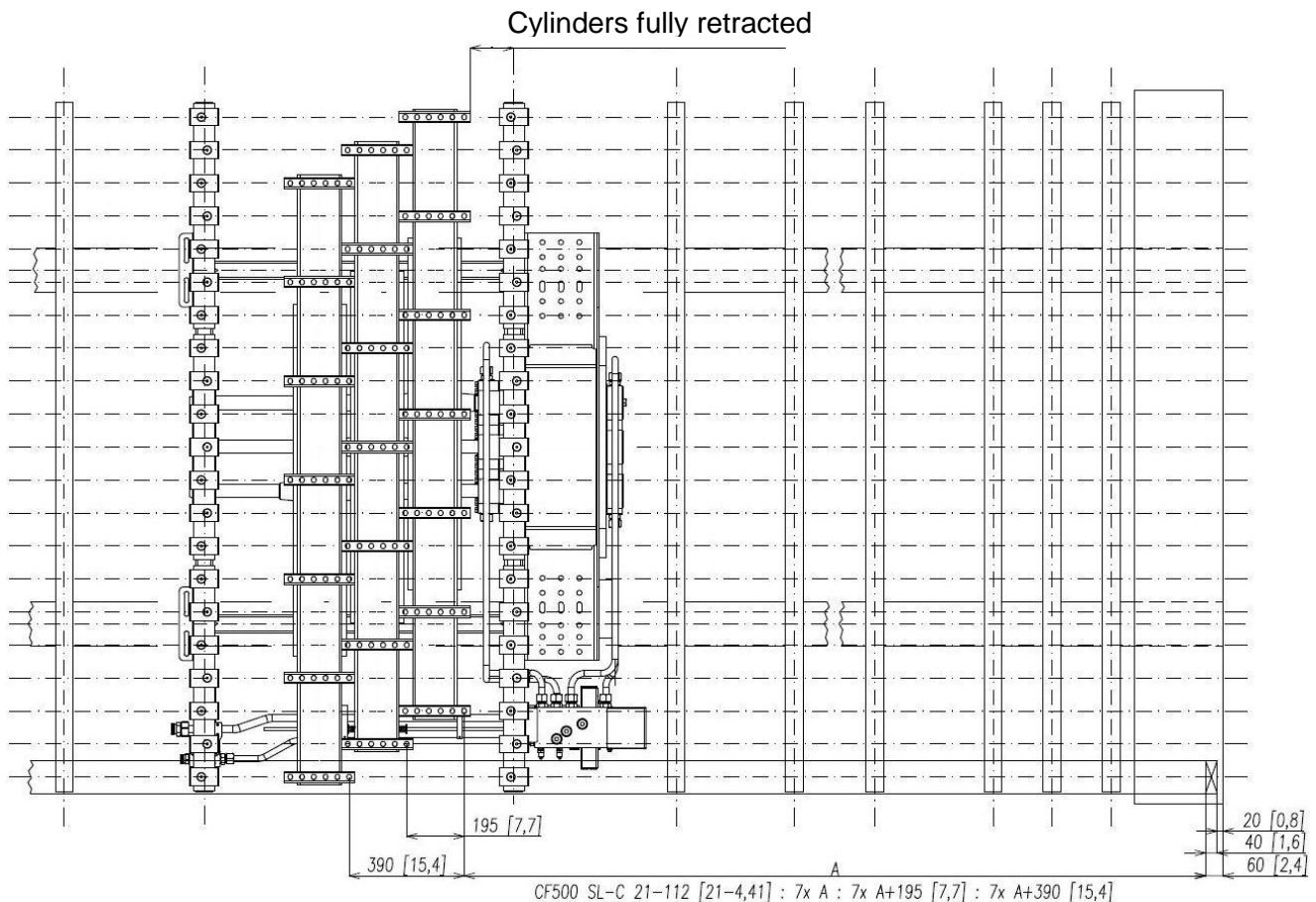
Put a mark on the bottom side of the 7 profiles of the 3rd group at the spot of this first hole.

The 7 profiles of group 3 will have the hole pattern on measurement A.

The 7 profiles of group 2 will have the hole pattern on measurement A + 195 mm [7.7"].

The 7 profiles of group 1 will have the hole pattern on measurement A + 390 mm [15.4"].

FIG. 17



DRILLING THE HOLES IN THE FLOOR PROFILES

The holes in the profiles need to be drilled before these are placed.

- Place all of the floor profiles with the sealing grooves in the same direction before you start drilling.
- Then drill according to figure 7 the necessary number of floor profiles per moving frame foot using the Cargo Floor drill jig, part number 9111009.
- Pre-drill 4 holes of $\varnothing 4.5$ mm [$\varnothing 0.18$ "] with the aid of the drill jig on the inside of the floor profile ensuring the centre of the holes line up with the extruded reference line. Then drill out the holes, from the same direction, to $\varnothing 12.5$ mm [$\varnothing 0.5$ "]. (fig. 9 A)
- Next the holes need to be countersunk from the top side using a good countersink bit according to the specification G136 HSS DIN 335 C, code 13628.0 (figure 9 B) Make sure that the hole is countersunk to the right depth; the screw head must not stick out above or under the floor profile. See figure 9 C.

FIG. 8

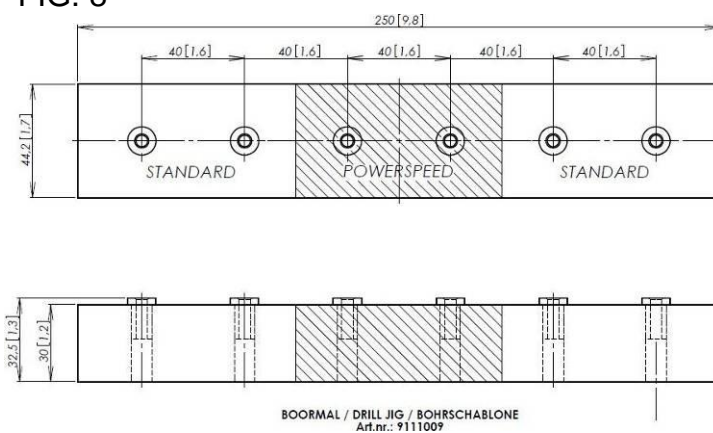


FIG. 9 A

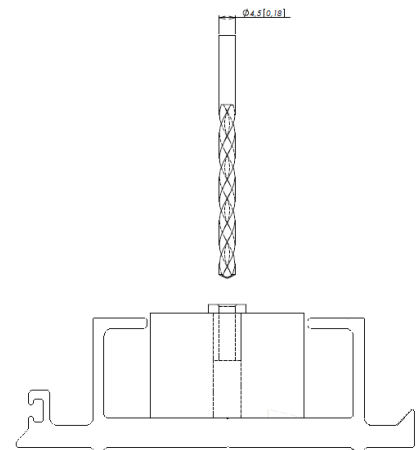


FIG. 9 B

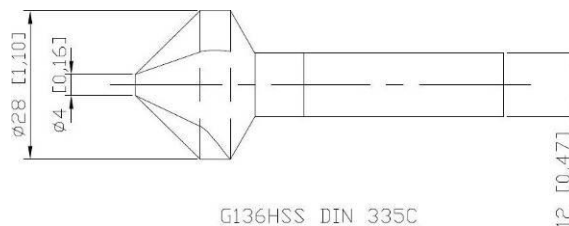


FIG. 9 C

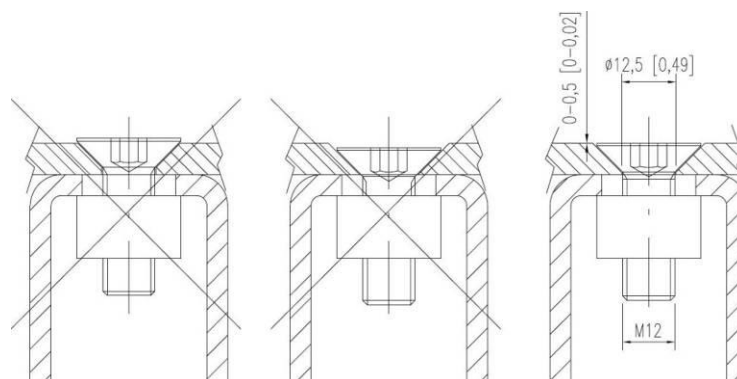
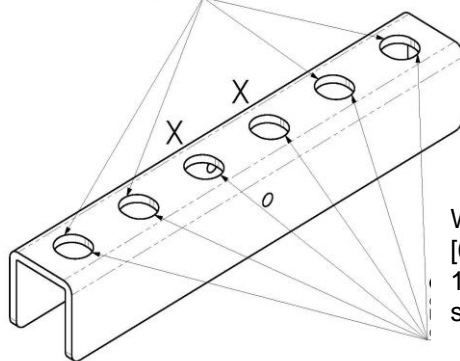


FIG. 9 D

STANDARD CARGO FLOOR-SYSTEMS

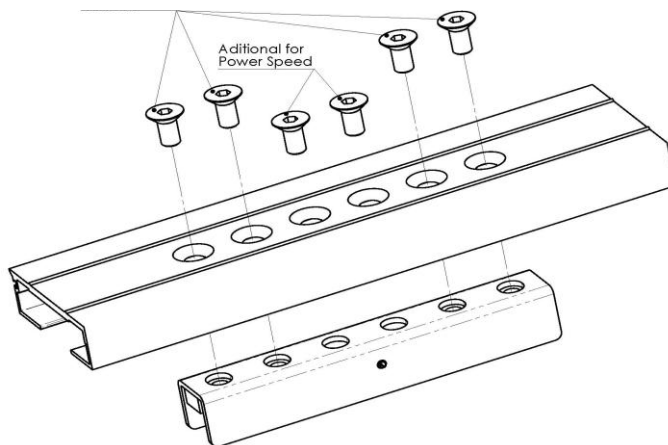
4 gaten gebruiken bij standaard CF systemen
Use 4 holes by standard CF systems
4 Locher benutzen bei den Standard CF Systeme



With special moving cross members (15/160 [6.3"], 15/156,8 [6.17], 18/112 [4.41], etc.) the profile should be fastened with 6 screws

FIG. 9 E

Only use the dedicated supplied screws:
M12 x 30- 10.9 DIN 7991



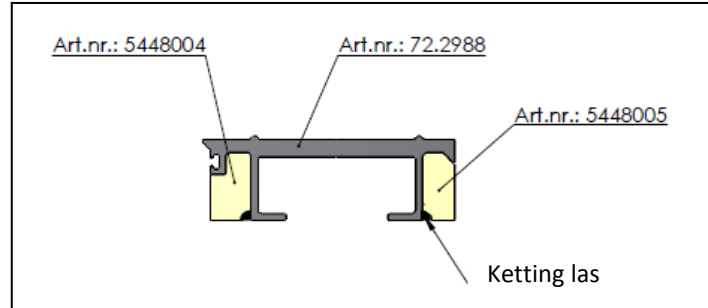
MOUNTING THE END BLOCKS AND SIDE CLOSING PROFILE

The end block Semi Leak Proof (5164004.1) can be hammered in the profile with a plastic hammer. It needs to be welded in order to fasten it. First weld the end block at the inside, top side, to the profile.

FIG. 10

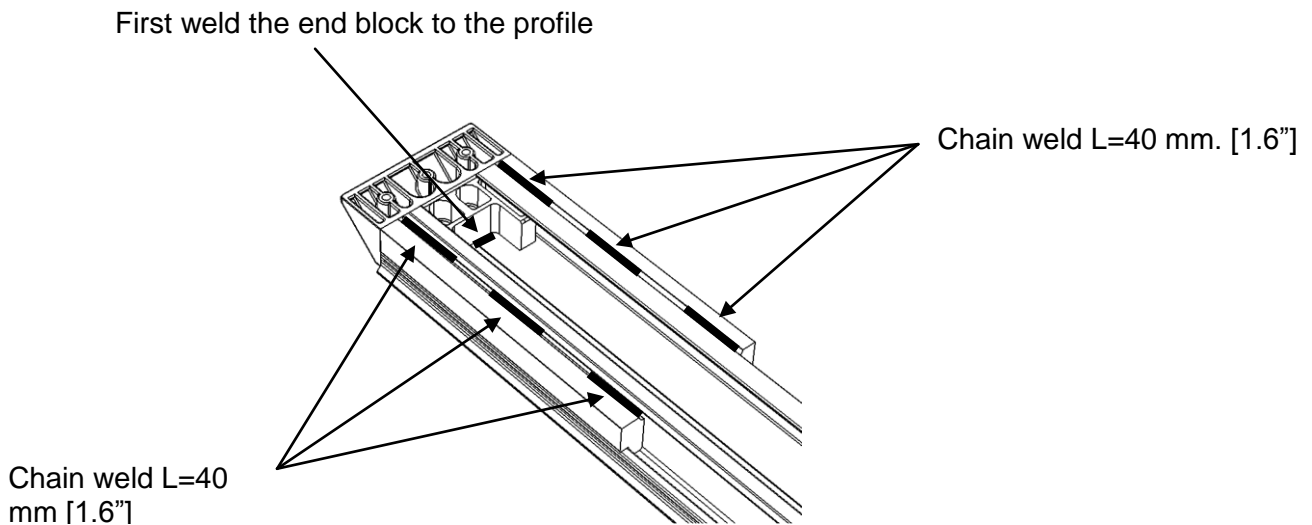


FIG. 11



Next the side closing profiles (alu side closing profile L.=220mm SLP seal side, art. no. 5448004 and alu side closing profile L.=220mm SLP NOT seal side art. no. 5448005) can be placed in the profile and against the end block. Press the closing profile well against the profile and the end block. Now weld both closing profiles starting in the middle with three chain welds of about 40 mm. [1.6"]. The weld may not protrude underneath the feet of the profile, so take care that the weld does not get too thick. Finish the welds so it is smooth and level with the feet of the profile.

FIG. 12



Now turn the profile and weld the top of the end block and profile over the full length.

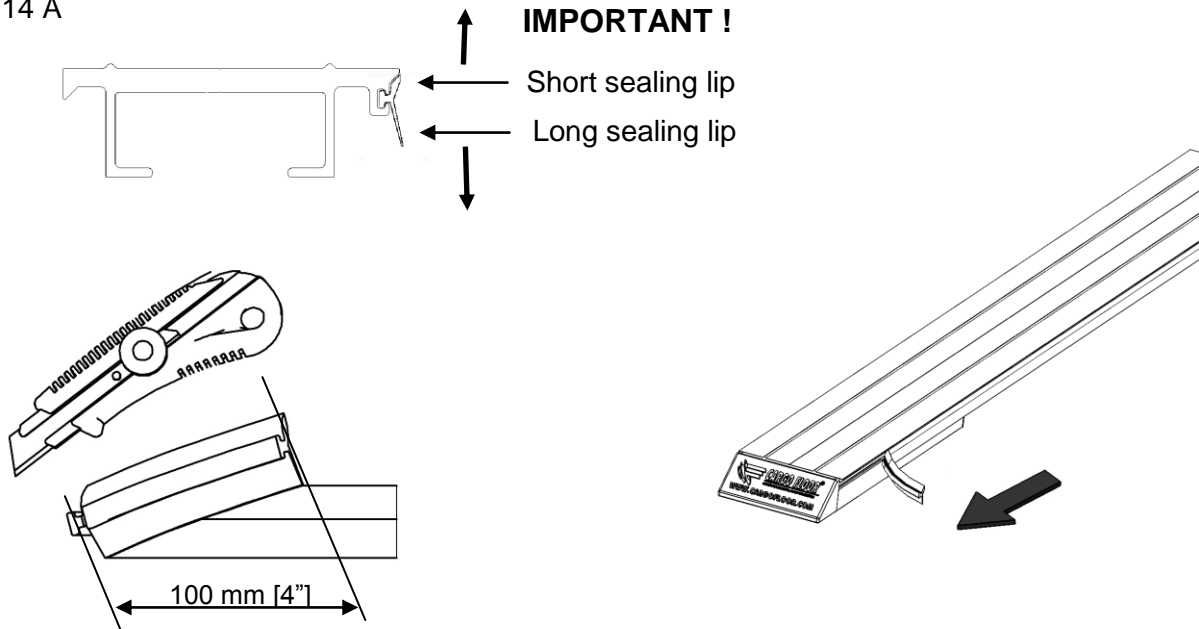


MOUNTING THE SEAL AND SEALBLOCK

Lay all of the floor profiles on their sides against one another, with the groove facing upwards. The groove in the floor profile needs to be clean (if necessary blown through with compressed air) before the seal can be mounted.

The seal is supplied on a roll. In order to install it simply, one needs to determine from which side of the groove the seal needs to be pulled. The short lip of the seal always needs to point upwards and the long lip needs to point downwards. See figure 14 A.

FIG 14 A

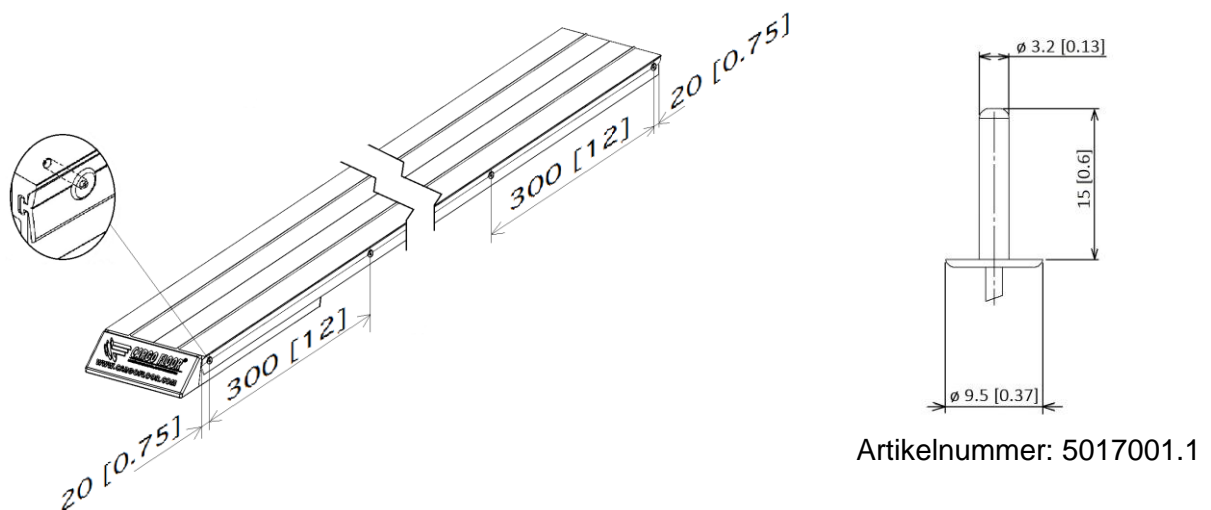


To aid the mounting of the seal, snip / cut about a little into the T-form at about 100 mm. [4"] from the start (this will form a handgrip, see figure 14 A).

Next, place the T section of the seal in the groove and, using the handgrip, pull the seal into the groove in the floor profile until the end of the floor profile. The cut will now be at the end of the floor profile. Now the seal can be fastened at one side with the special rivet (article no. 5017001.1, see fig. 14 B).

Then tension the seal by stretching it by at least 600 to 1000 mm [24" to 40"] (until you start to feel higher resistance and the length of the vehicle), this means about 6 to 10 kg [13 to 22 lbs]. pulling force. After tensioning the seal place the remaining pop-rivets according to figure 14 B.

FIG. 14 B



SECURING THE FLOOR PROFILES TO THE DRIVE UNIT

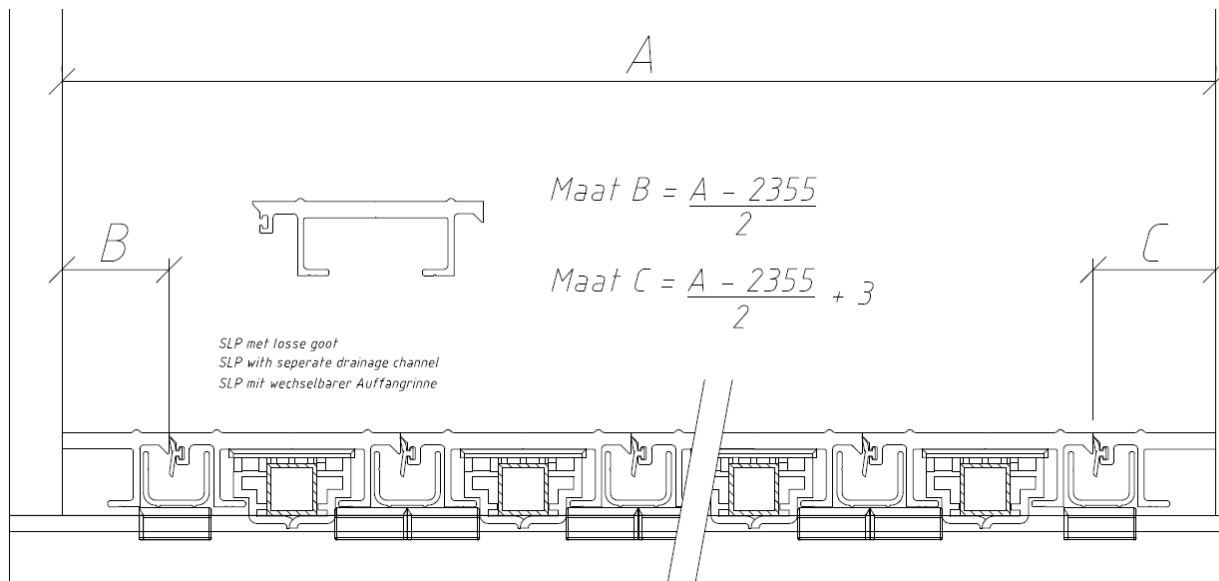
After the floor profiles have been cut to size, rounded-off, drilled, and had the seals and sealblocks mounted, they can be slid over the plastic bearing at the required position (matching up the hole pattern with respect to the moving crossmember). You need to carefully guide the floor profiles during the mounting procedure. Next, mount the provided galvanized M12 bolts with countersunk head using Allen No. 8. A torque of 100 – 140 Nm [72 – 105 lbf.ft]. should be used to tighten the bolts. One person can do this from above, and the bolts need to be well tightened. (fig. 9 E). Every bolt should be fitted with Loctite (Loc-tite 243 cat.o. 23286 screw thread locker).

SECURING THE STATIONARY SIDE PROFILES

The stationary side profiles always need to be mounted 2 mm. [0.08"] lower than the moving floor profiles (see figure 15). The stationary edge profiles need to be pushed firmly against the moving floor profiles before the stationary profiles are secured. Next the stationary edge profiles need to be secured every 1500 to 2000 mm [5' to 6,6'] with mono-bolts, with countersunk heads, which are not permitted to stick out above the edge profile (see figure 15). The opening between the sidewall and the stationary profile needs to be filled with a flexible sealant.

Alternatively you can mount it with a bolt connection or make small welds.

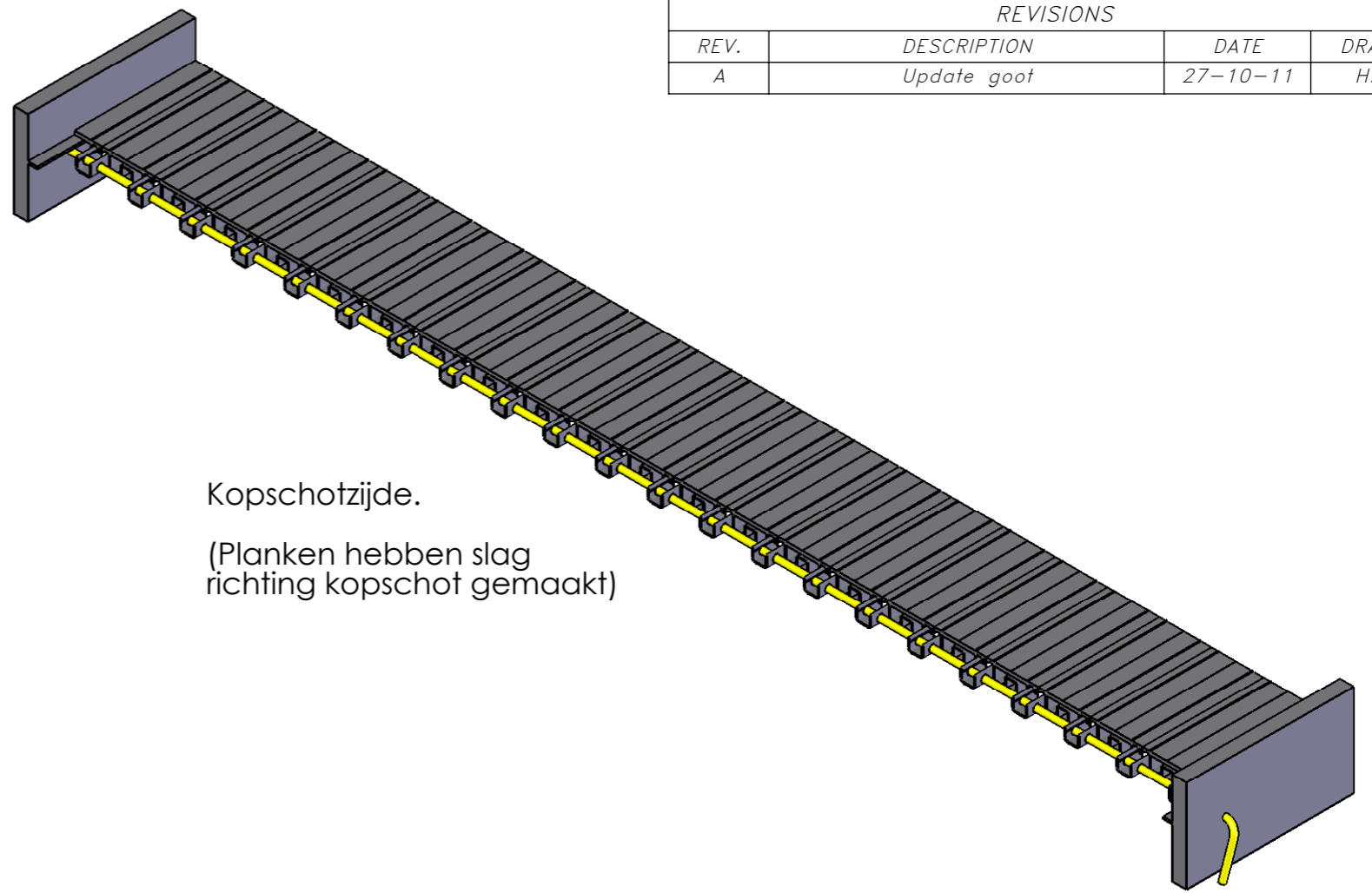
FIG. 15



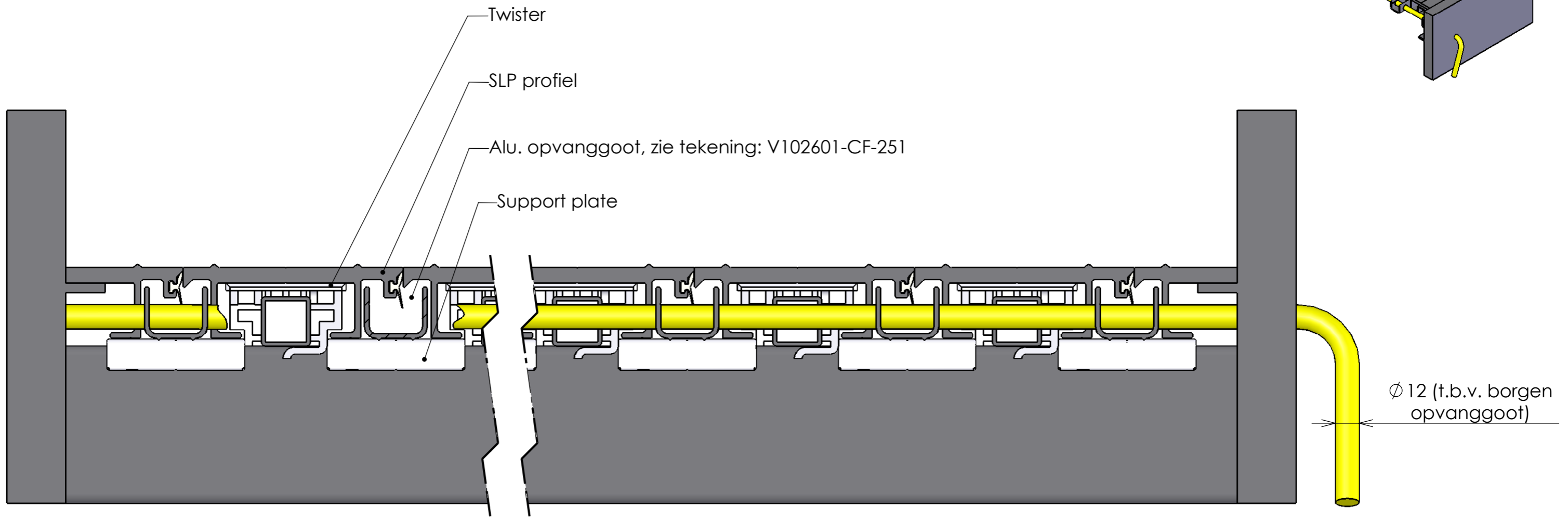
It is better not to weld the stationary edge profiles completely to the sidewalls, since at a later stage the floor may need to be retensioned, and to do this the side planks need to be loosened.

FOR INFORMATION ONLY !

REVISIONS			
REV.	DESCRIPTION	DATE	DRAWN
A	Update goot	27-10-11	H.Z.



Kopschotzijde.
(Planken hebben slag richting kopschot gemaakt)



Kopschotzijde.



Cargo Floor B.V.
P.O. Box 271
NL-7740 AG Coevorden
Phone : +31-524-593900
Fax : +31-524-593999
E-mail : info@cargo-floor.nl

Project:

Vloerprofielen

Subject:

Borgen opvanggoot 755.4525 i.c.m. SLP profiel

Date: 7/2/2010

Drawn: H.Z.

Drw. nr.:

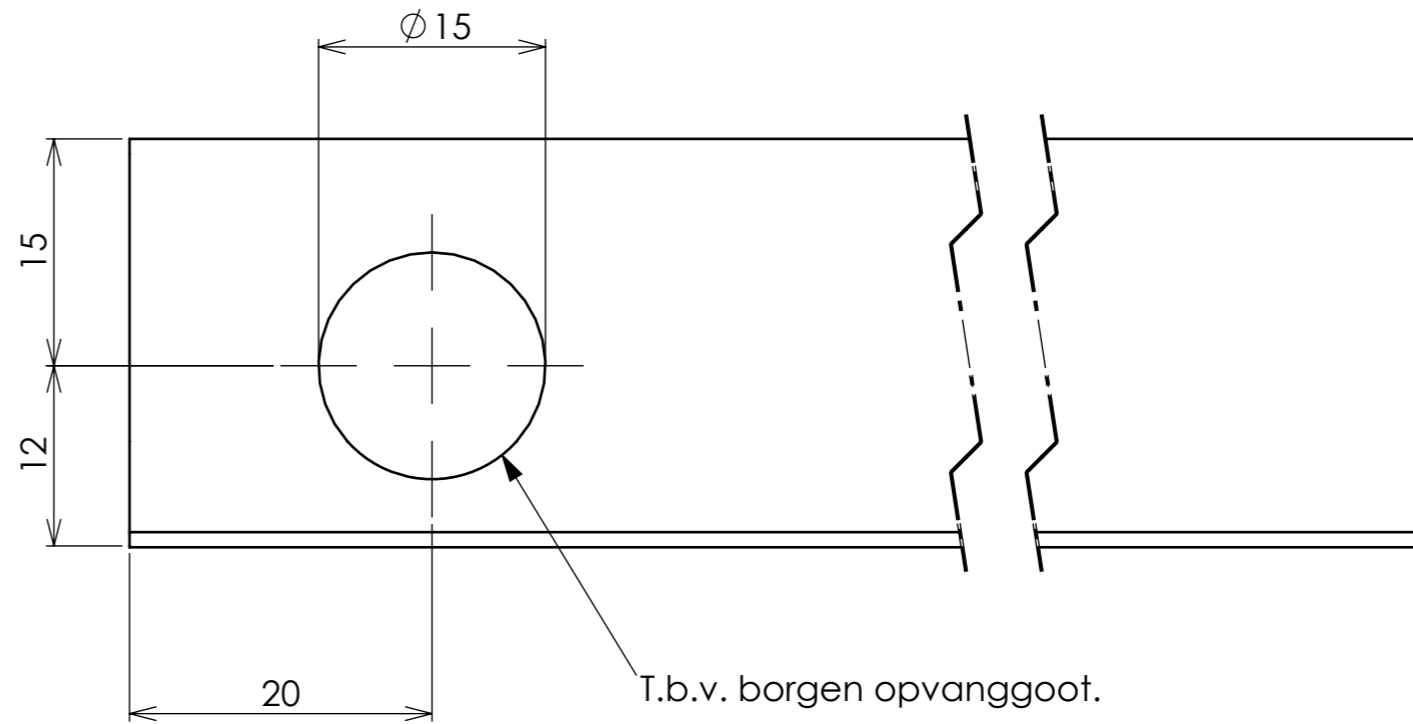
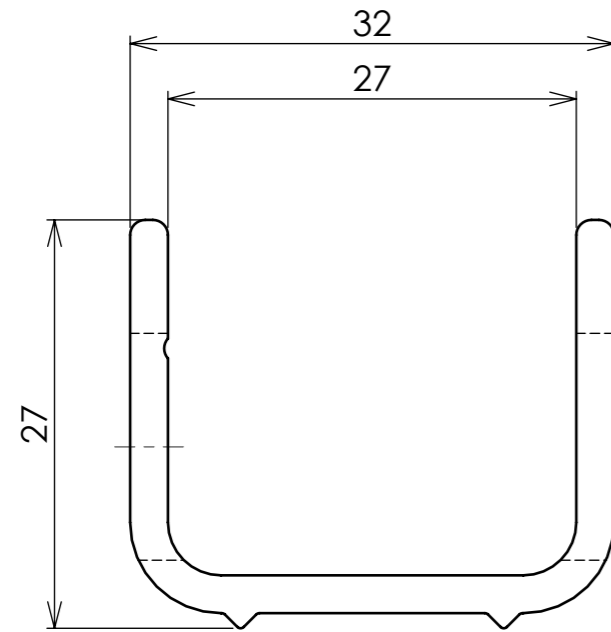
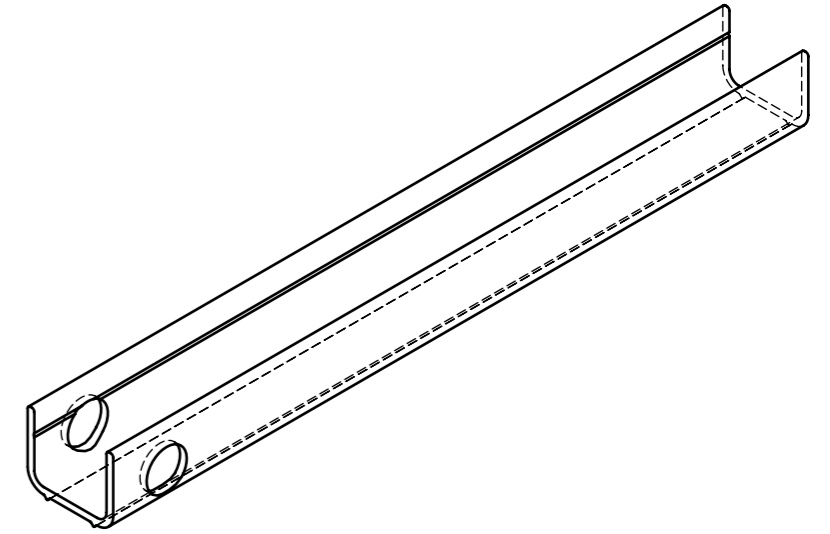
V102601-CF-250

A3

This drawing and the information contained herein is for general presentation purposes only.
This drawing is not intended for use on engineering plans and can be used as "as-is".
This drawing is the property of Cargo Floor b.v. and must not be copied or reproduced without their written authority.

FOR INFORMATION ONLY !

REVISIONS			
REV.	DESCRIPTION	DATE	DRAWN
A	Update goot	27-10-11	H.Z.



Cargo Floor B.V.
P.O. Box 271
NL-7740 AG Coevorden
Phone : +31-524-593900
Fax : +31-524-593999
E-mail : info@cargo-floor.nl

Project: **Vloerprofielen**

Subject: **Borgen opvanggoot (artikelnr. 755.4525)**

Date: 7/2/2010

Drawn: H.Z.

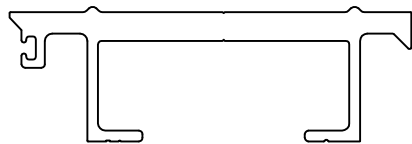
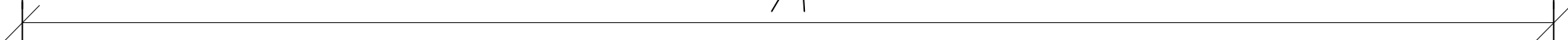
Drw. nr.:

V102602-CF-251

A3

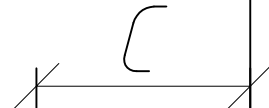
This drawing and the information contained herein is for general presentation purposes only.
This drawing is not intended for use on engineering plans and can be used as "as-is".
This drawing is the property of Cargo Floor b.v. and must not be copied or reproduced without their written authority.

A

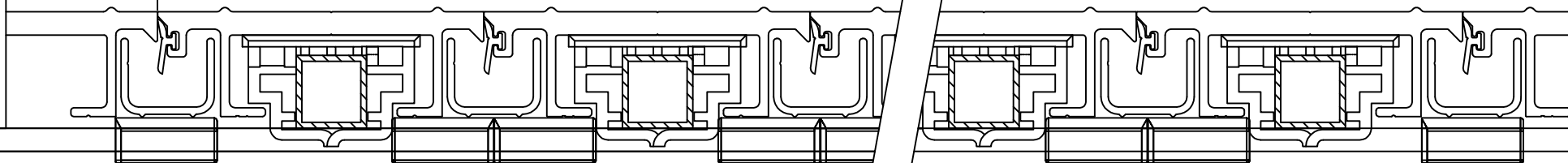


$$\text{Maat } B = \frac{A - 2355}{2}$$

$$\text{Maat } C = \frac{A - 2355}{2} + 3$$



SLP met losse goot
 SLP with separate drainage channel
 SLP mit wechselbarer Auffangrinne



Phone: +31-524-593900 Fax: +31-524-593999

Cargo Floor B.V.
 Byte 14
 NL-7741 MK Coevorden
 P.O. Box 271
 NL-7740 AG Coevorden
 E-mail: info@cargofloor.nl



PROJECT:
SLP met losse goot
 SUBJECT:
Impressie SLP planken

All rights strictly reserved. Reproductions or issue to third parties in any form whatever is not permitted without written authority from the proprietor.

ORDER:

DATE: 12-03-10

DRAWN: H.Z.

REV	DATE	CHANGES	BY
B	27-10-11	Update goot	HZ
A	07-09-10	+Support plate	HZ

PAGE

...

DRAWING NUMBER :

V101012-CF-201