

It is advised to read the mounting instructions carefully before mounting the protection sheet and roll mechanism.

This protection sheet protects your aluminium floor profiles against aggressive and corrosive cargos, and cargos that can lead to a to large friction resistance between the profiles.

TABLE OF CONTENTS

Parts supplied.....	1
Parts supplied with a pneumatic operation.....	2
Mounting the tarpaulin.....	2
Mounting the pneumatic drive.....	4
Finishing.....	5
Survey drawing.....	6
Contact data.....	6

PARTS SUPPLIED

Protection sheet provided with lacing. L. 14.000 mm.

Aluminium bearing profile L. 2.500 mm.

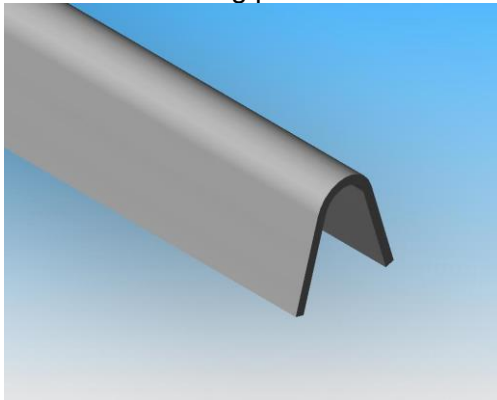

Roll up axle floor tarpaulin, L. 2.500 mm.

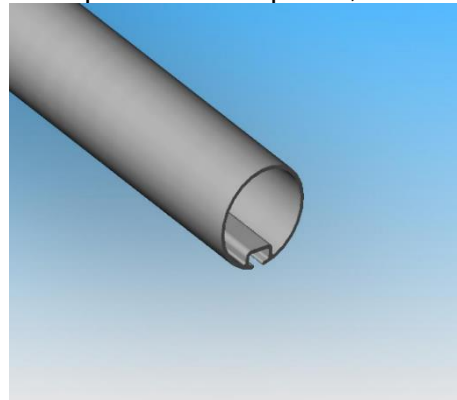

Bearing holders and bearings

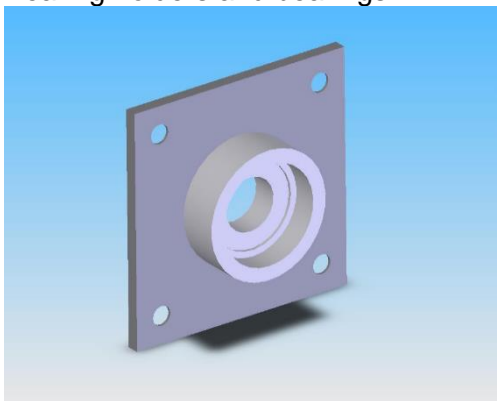

Bearing and rod adapters

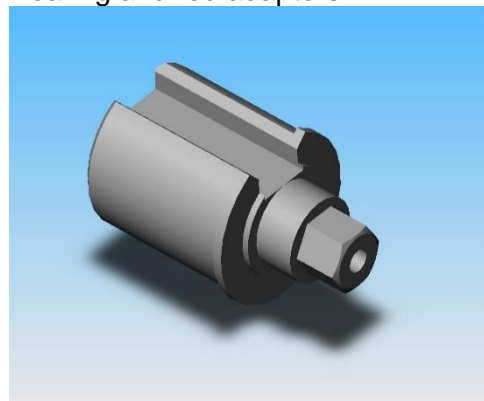

Mounting plates

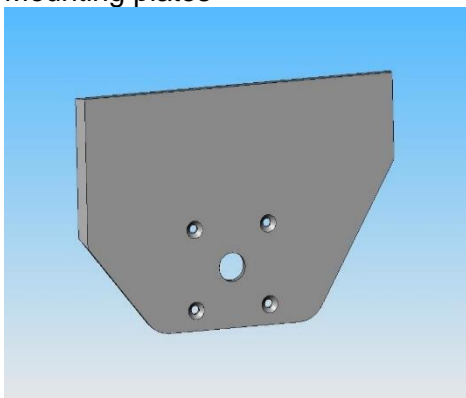

A manual key

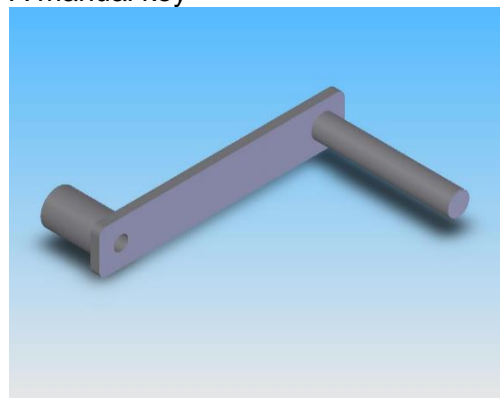

PARTS SUPPLIED WITH A PNEUMATIC OPERATION

- 8 mm. connection material;
- A two position valve;
- A pneumatic wrench with brace, hose and quick couplings.



MOUNTING THE TARPAULIN



Before mounting one must determine at which spot enough room is available in order to mount the roll. With most bodywork this is possible directly under the rear portal of the trailer. Pay attention to that you do not cover the lights.

Determine the position of the mounting plates

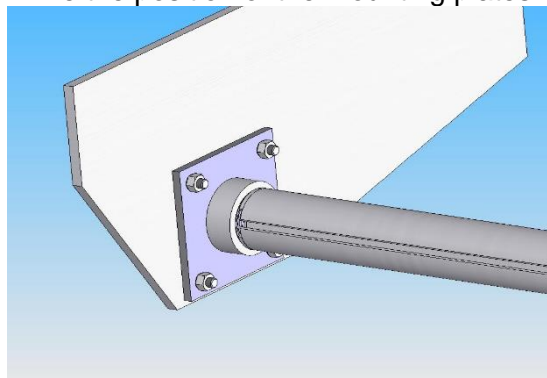

When the position is determined one can start with mounting the mounting plates onto the rear portal. Pay attention to that the axle is hanged horizontally comparatively to the floor of the trailer.

Positioning of the bearing profile



Cut the guiding profile in parts so these can be welded or mounted between the door locks the sharp edges. This profile is used to prevent the sheet getting stuck behind the lock brackets of the trailer.

Take care that if you have a pneumatic door lock this brace can tilt away far enough.

When the mounting plates are mounted, the bearing plates and ball bearings can be mounted and the adaptors can be pushed into the ball bearings. The length of the roll up tube can be determined.

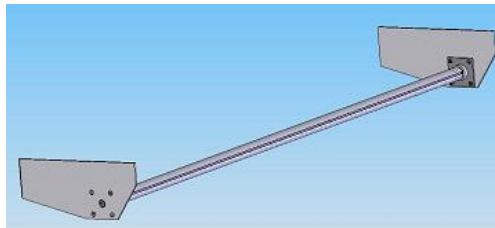

The width of the protection sheet is determined by the width of the inside of the trailer with on each side 1 cm. space. (This means, width floor – 2 cm.)

The adaptor must be pushed into the tube. After this the protection sheet with the lacing must be put into the rail of the tube and rolled up. Remove the bearing plates from the mounting plates and putt these on the adaptors the whole can be pushed between the mounting plates and after this the bearing plates can be fastened.

MOUNTING THE PNEUMATIC DRIVE

A connection must be made to the accessory air circuit if you have a pneumatic roll mechanism for the protection sheet. After this the two position valve must be mounted on the chassis so the driver can simply operate this valve nearby and can supervise the unloading

This valve must contain a quick coupling. The hose must be mounted on the pneumatic wrench. The clamping brace for the pneumatic wrench must be positioned on the mounting plate. Mind that these must be de-mountable regarding the legal max. trailer width. (Use for this for instance a winged bolt.) The pneumatic wrench can be fixed in the brace.

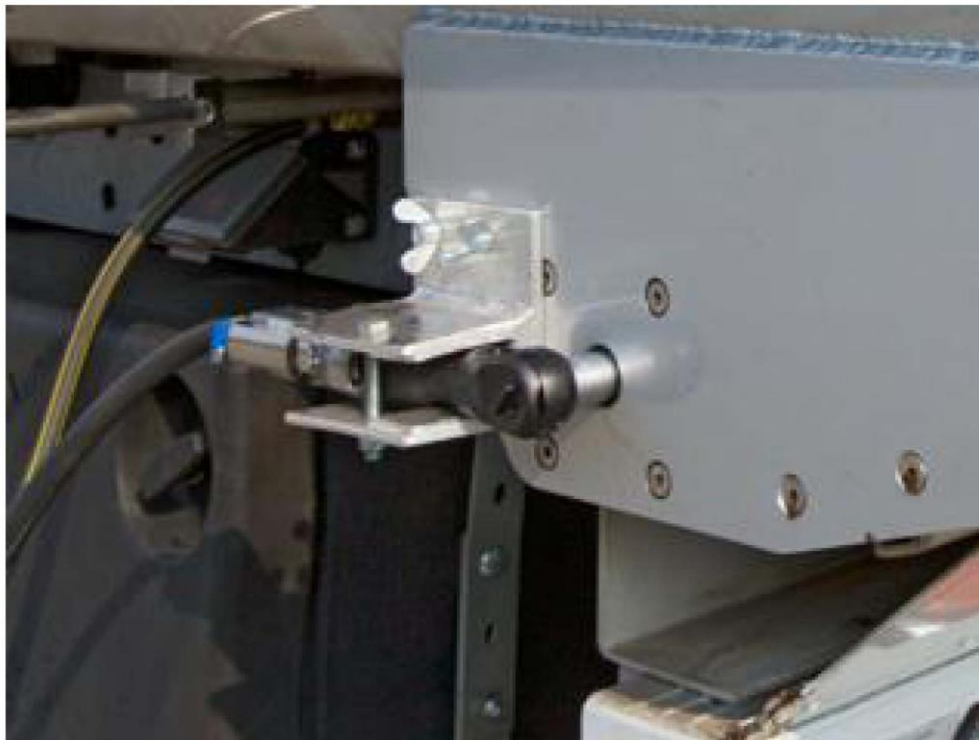

FINISHING

Roll the protection sheet fully out to the headboard of the trailer. If necessary it can be shortened on the headboard side and equipped of a loop for the tube \varnothing 20 mm. Holes must be cut into the sheet at the position of the locks of the doors. The doors can then be locked while the protection sheet is rolled out over the floor.

After this the mechanism is ready for use.

Before loading roll the protection sheet over the floor. After this the load can be loaded. When unloading the pneumatic wrench incl. brace on the plate must be placed and the two position valve must be opened. If you want the wrench to operate automatically you can wrap a rubber band or tape around the handle so the handle remains pushed in.

When unloading, every stroke will automatically roll up the protection sheet. Do take care that no material behind the trailer pushes against the mechanism.

Advice:

Fabricate a covering plate to protect the sheet when it is not used.

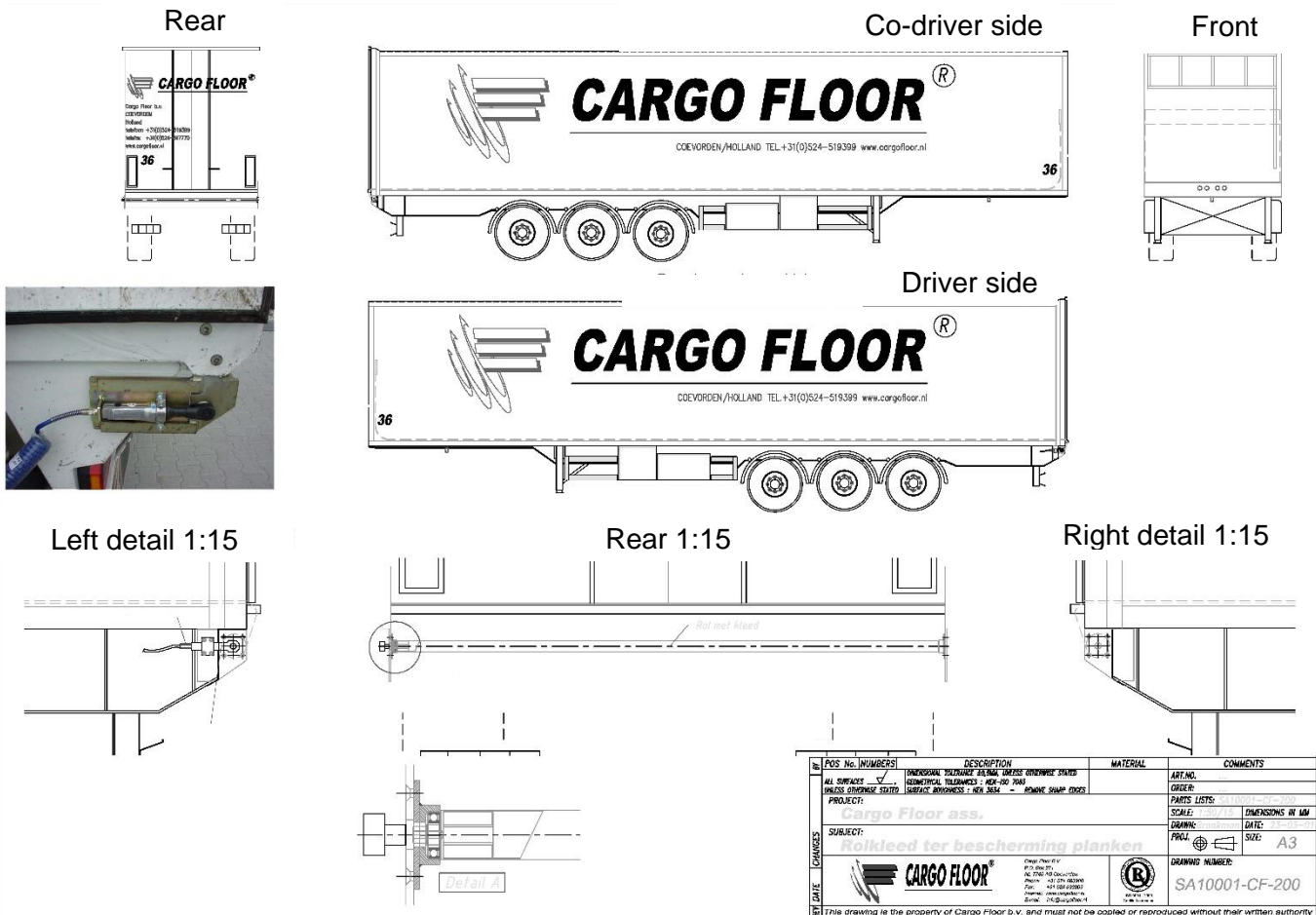
SURVEY DRAWING

CONTACT DATA
Postal and visiting address:

Cargo Floor B.V.
 Byte 14
 7741 MK Coevorden
 The Netherlands

Phone number: +31 524 593 900
 E-mail: info@cargofloor.com
 Website: www.cargofloor.com

Order spare parts:

E-mail address: sales2@cargofloor.com
 DID number: +31 524 593 922

After Sales (technical questions and malfunctions)

E-mail address: as@cargofloor.com
 DID number: +31 524 593 981 / +31 524 593 991

Coevorden, The Netherlands

© 2017 Cargo Floor B.V.

No part of this publication may be reproduced, stored in a retrieval system, or transmitted, in any form or by any means, electronic, photocopying, recording or otherwise, without the prior permission of Cargo Floor B.V.